



HCA PUMP

Applications:

- Cutting, turning, milling, boring, grinding and similar applications of the machine tools,
- Cooling systems,
- Circulation systems. HCA Pumps are used for pumping of cutting / cooling fluids.

Fluid Specifications:

- Coolants,
- Cutting oils,
- Grinding oils,
- Water,
- Fluid temperature 0...80 °C
- Kinematic viscosity 1...30 mm²/s

Materials:

Pump body	: Cast iron - DIN GG 25
Bottom plate	: Sheet iron
Diffuser	: Stainless steel - DIN 4301 (AISI 304)
Impeller	: Stainless steel - DIN 4301 (AISI 304)
Strainer	: Stainless steel - DIN 4301 (AISI 304)
Pump shaft	: Stainless steel - DIN 4401 (AISI 316)
O-ring	: Viton
Mechanical seal	: C - SiC - Viton TC - TC - Viton (Optional)
Electric motor	: 3 phase induction motor - 2 pole, Protection degree IP 55

DIMENSIONS & NOMINAL VALUES

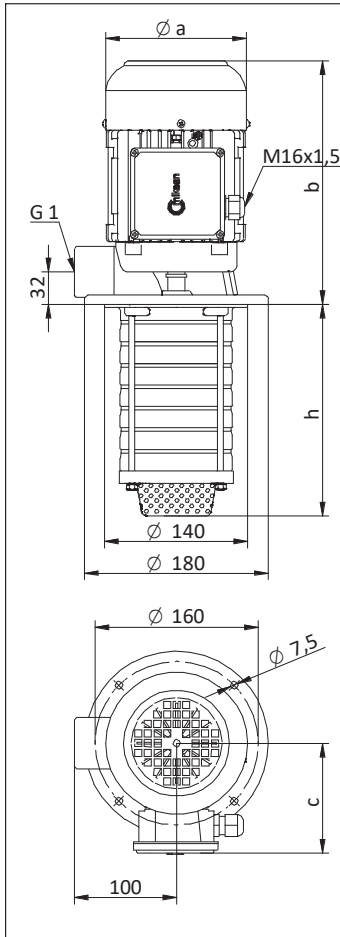

TYPE	Depth of immersion h (mm)	a	b	c	Weight kg	Power kW	Voltage V(Δ/Y)	Frequency Hz	Rated current A	Speed rpm
		mm								
HCA/02	143	138	240	111	10.1	0.37	230/400	50	1.84/1.05	2790
HCA/03	143				11.4	0.55			2.25/1.3	2780
HCA/04	164				13.3	0.75			3.12/1.8	2820
HCA/05	185				13.6	1.10			4.85/2.8	2720
HCA/06	206				13.8	1.10			4.85/2.8	2720
HCA/07	227				14.0	1.10			4.85/2.8	2720

* The performance curves are based on $1 \text{ mm}^2/\text{s}$ (cSt) kinematic viscosity values and 997 kg/m^3 density
 ** Curve tolerance according to ISO 9906:2012 Grade 3B.
 *** HCA/05, HCA/06 and HCA/07 pumps have IE2 motors. According to IEC 60034-30-1:2014 standard these pumps are excluded from efficiency class since their motors are completely integrated into the pump.

Performance Curve

